

Industrial Laser System for Material Processing

Activation Series

	<p>Features</p> <ul style="list-style-type: none"> • Silica fiber • High precision • High stability 	<p>Applications</p> <ul style="list-style-type: none"> • Advanced manufacturing • Healthcare • Information technology • Scientific research
-----------------------------------------------------------------------------------	---------------------------------------------------------------------------------------------------------------------------------------------	----------------------------------------------------------------------------------------------------------------------------------------------------------------------------------------------

Product Dimensions (mm)

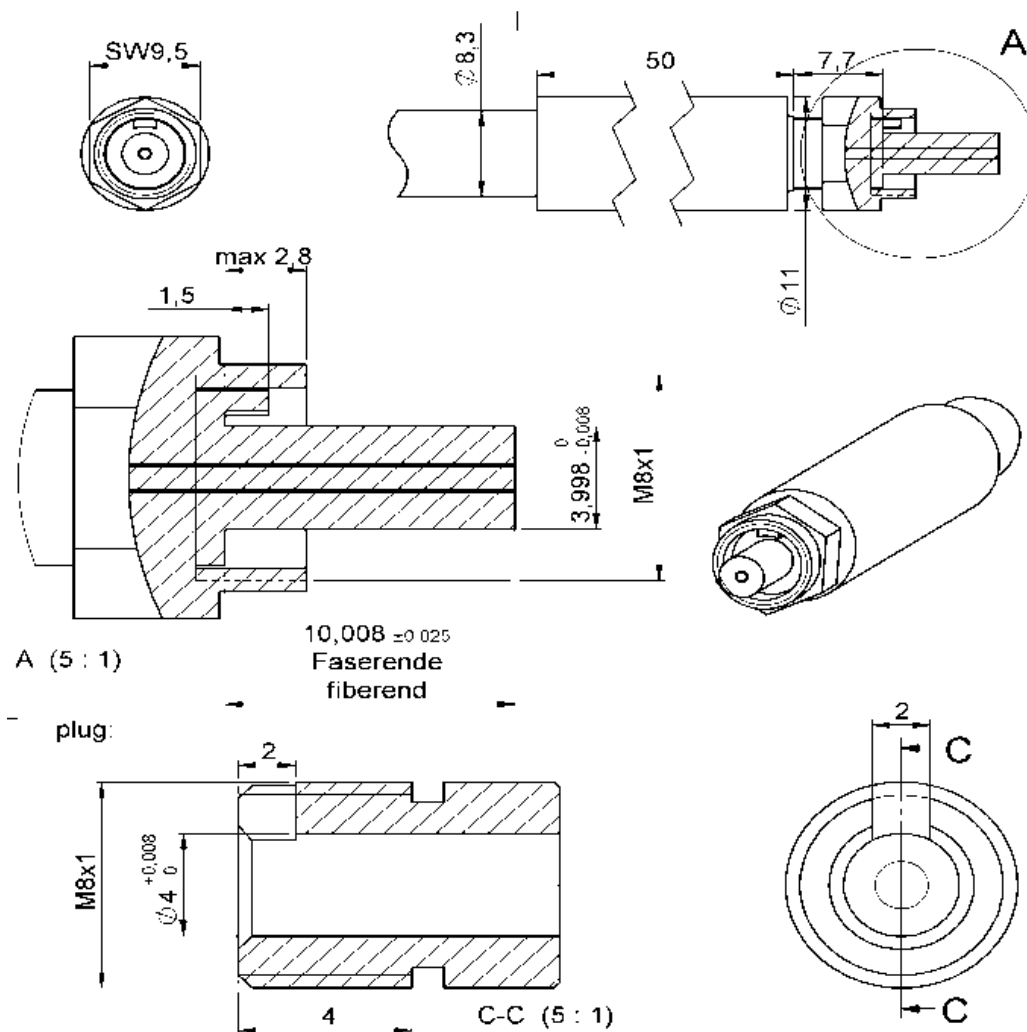

Remark: The structure drawing is for reference only. Please feel free to contact us for any special requirements.

Product Specifications

Product Code	ACT000002	ACT000001
Part No. ¹	LM-LD80-F400-5	LM-LD80-F400-10

General Data	Unit	Value	
Fiber Core Diameter	µm	400	400
Fiber Cladding Diameter	µm	480	480
Cable Diameter	mm	8.25	8.25
Length	m	5	10
Minimum Bending Radius	cm	14.4	14.4
Fiber Connector 1	-	LD80	LD80
Fiber Connector 2	-	LD80	LD80
Fiber Jacket	-	High Protective Metal	High Protective Metal
Fiber Jacket Coating	-	PVC	PVC

Optical Data			
Wavelength Range	nm	600-1700	600-1700
Numerical Aperture	-	0.22	0.22
Max. Acceptable Laser Power	W	500	500

¹ Part No. = Brand Code - Connector Type - Fiber Diameter - Fiber Length

